



## مقدمة

تم انشاء مصنع الريادة الآلي للألمنيوم في عام ٢٠١٠ بمساحة تبلغ ٢٥٠٠٠ م2 بمدينة الرياض وتم تجهيزه بأحدث المعدات والآلات الحديثة والمتطورة واللازمة لتنفيذ جميع الأعمال وبمهنية ودقة عالية كمان تم تزويده بكادر عمل متميز من المهندسين والفنيين الذين يملكون خبرة عالية في هذا المجال وذلك لنواكب التطور المستمر في هذا المجال ولنلبي احتياجاتكم وبشكل دائم ومستمر، ونحن نسعى بشكل دائم لكسب ثقتكم ورضاكم ونعمل جاهدين على الوفاء بوعودنا والتزاماتنا امامكم ونقوم بتقديم الافضل لعملائنا وبأعلى الموصفات وبأقل التكاليف .



## الهيكل الإداري للمصنع

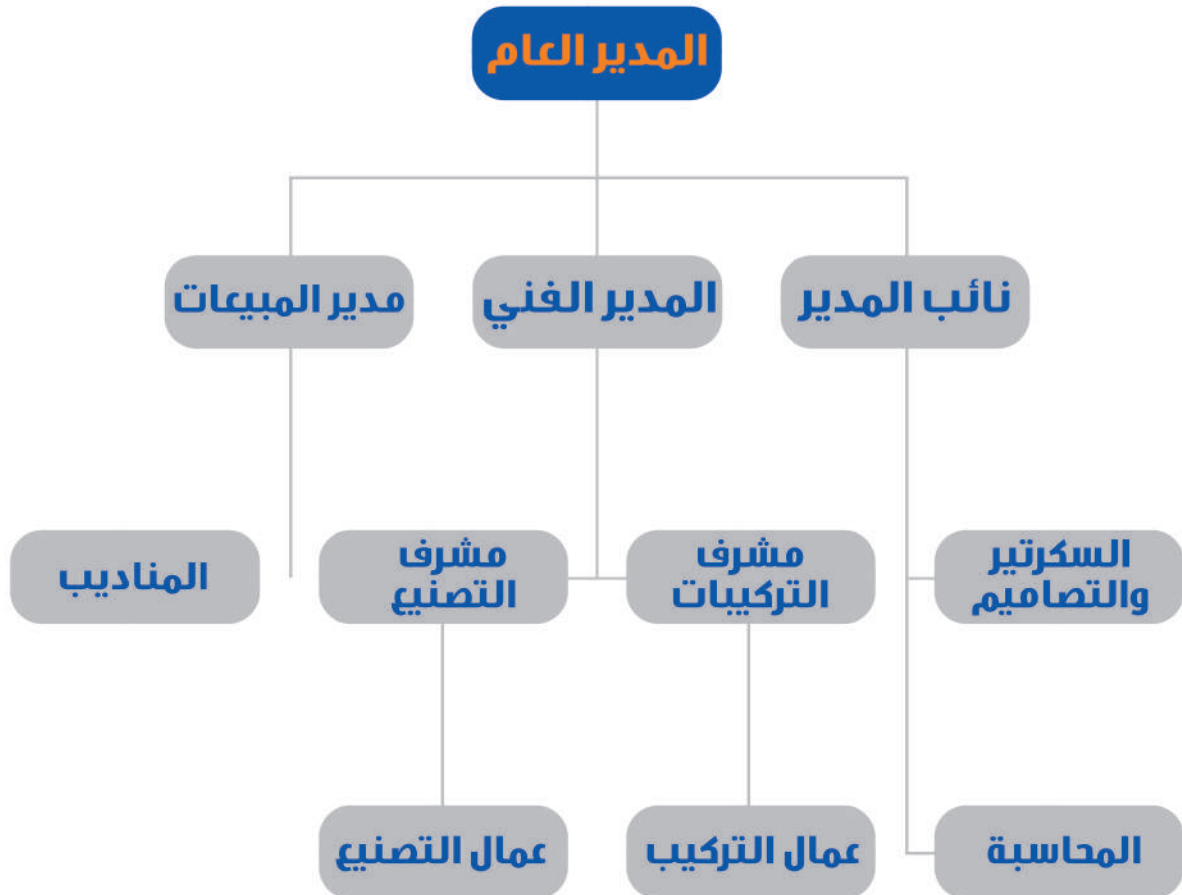



وزارة التجارة  
Ministry of Commerce

# شهادة تسجيل فرع مؤسسه

الرقم: ٧٠٠٤٤٠٠٦٨٠  
١٠١٠٣٠٦٤٩٣  
التاريخ: ١٤٣٢/٠٥/٢ هـ

اسم التاجر: سعد مشرف عبدالله العمري  
رقم السجل المدني/بطاقة الأحوال: ١٠١٩٥٢١٩٦٠ : تاريخه: ١٤٣٠/٠٦/٢٧ هـ الجنسية: سعودي  
المركز الرئيسي: الرياض  
ص.ب: ١٣٢٢٥ هاتف: ١٣٢٢٥  
الرمز البريدي: ١٠١٠٤٨٦٠٩٣

رقم سجل المركز الرئيسي: ١٠١٠٤٨٦٠٩٣  
الاسم التجاري للفرع: مصنع الريادة الآلي للصناعات المعدنية  
العنوان: ٨٣٠٢، الطليعة، السلي، ٤١٢٢  
ص.ب: ١٤٣٢٢ هاتف: ١٤٣٢٢  
الرمز البريدي:

النشاط: صناعة الهياكل المعدنية وأجزائها للجسور والأبراج، صناعة المباني سابقة الصنع المكونة بصفة رئيسية من المعدن، صناعة وتركيب النوافذ والأبواب، صناعة وتركيب  
المطلات

رأس المال: ٢٩٧٥٠٠  
اسم المدير أو الوكيل المفوض: سعد مشرف عبدالله العمري  
الجنسية: سعودي  
رقم السجل المدني - الإقامة: ١٠١٩٥٢١٩٦٠  
سلطات المدير

يشهد مكتب السجل التجاري بمدينة الرياض بأنه تم تسجيل هذه المؤسسة بسجل مدينة الرياض  
وتنتهي صلاحية الشهادة في ١٤٤٦/٠٣/٠١ هـ بموجب الإصدار رقم: ٤٤٢٤١١ و تاريخ: ١٤٣٠/٠٦/٢٧ هـ  
تاريخ الميلاد: ١٣٤٥ هـ  
مصدره: أحوال مقر الوكالة با



مدير السجل التجاري:  
التوقيع:  
ليف صالح الطاسان

To Verify the information of this certificate visit <http://v.mci.gov.sa> يمكنك التحقق من صحة هذه الشهادة بالدخول على



تاريخ الإصدار: 2020/09/04  
الرقم المميز: 3020512851



الهيئة العامة للزكاة والدخل  
General Authority of Zakat & Tax



## شهادة تسجيل في ضريبة القيمة المضافة VAT Registration Certificate

تشهد الهيئة العامة للزكاة والدخل بأن المكلف أدناه مسجل في ضريبة القيمة المضافة  
بتاريخ 2018/02/25

Hereby, The General Authority of Zakat & Tax (GAZT) certifies that the taxpayer below is  
VAT registered on 25/02/2018

اسم المكلف:	مؤسسة سعد مشرف العمري للمقاولات العامة
رقم التسجيل الضريبي:	302051285100003
تاريخ نفاذ التسجيل:	2018/03/01
عنوان المكلف:	الرياض، الرياض اشبيلية شارع، 13225



كمكلف مسجل في ضريبة القيمة المضافة، لا يجوز لك تحصيل ضريبة القيمة المضافة من عملائك قبل تاريخ نفاذ التسجيل بالضريبة. في حال تبين غير ذلك، ستقوم الهيئة العامة للزكاة والدخل بتنفيذ الغرامات المستحقة

هذه الوثيقة مرسله من النظام الآلي ولا تحتاج إلى توقيع  
- الهيئة العامة للزكاة والدخل -



الغرفة التجارية والصناعية بالرياض  
Riyadh Chamber of Commerce & Industry

## شهادة الاشتراك ٢٠١٤ م Certificate of Membership 2014

القطاع التنفيذي

الإدارة العامة لخدمات الاشتراكات

إدارة شؤون العضوية

Unified Membership No. : 101000 279051

Date of Issue : 08/01/2014

Classification : Third

Riyadh Chamber of Commerce and Industry certifies that:

Commercial Register No 1010306493

Registered for this year.

The Certificate expires on 31/12/2014

رقم العضوية الموحد : ١٠١٠٠٠٢٧٩٠٥١

تاريخ الأصدار: ٢٠١٤/٠١/٠٨

الدرجة: الثالثة

تشهد الغرفة التجارية الصناعية بالرياض بأن :

مصنع الريادة الألي للالمنيوم

المقيدة بالسجل التجاري / الترخيص رقم ١٠١٠٣٠٦٤٩٣

مشتركة لديها لهذا العام .

ويتهي سريان هذه الشهادة في ٢٠١٤/١٢/٣١ م

فاكس:

هاتف: 2417258

الرمز:

ص. ب:

مدير عام الاشتراكات

ختم الغرفة



اي كشط او تعديل في هذه الشهادة يلغيها



## ترخيص منشأة صناعية - وطني

رقم ( ٧٧٢ ) بتاريخ: ٢٠٢١/٠٣/٢١ هـ ١٤٤٠

تعديل للترخيص رقم ( ٣٢٤٥ ) بتاريخ: ١٩/١١/١٤٤٣ هـ

وزارة الطاقة والصناعة والثروة المعدنية  
Ministry of Energy

١٠١٠٣٠٦٤٩٣	السجل التجاري للمنشأة	٣٤١٤٤٥	رمز المنشأة	مصنع الريادة الآلي للالمنيوم	اسم المنشأة
١٢٧٠٢٠٨٦	فاكس	١٢٧٠٢٠٨٦	هاتف	الرياض (N24.6204271 - E46.8491695)	موقع المنشأة
				سعد مشرف عبدالله العمري ( رقم الهوية: ١٠١٩٥٢١٩٦٠ / الجنسية: السعودية )	ملكية المنشأة
				٢٣١٠ - صنع الزجاج والمنتجات الزجاجية	النشاط الرئيسي

## النشاط الصناعي

النشاط الصناعي	وصف المنتج	رمز المنتج	الوحدة	الطاقة الإنتاجية
٣٣١٠٢١ - صناعة الأصفاد الزجاجية المعزلة المستخدمة في الإنشاءات	زجاج مضق	٧٠٠٧١٩٠٠	طن	٢٠٠
٣٣١٠٢١ - صناعة الأصفاد الزجاجية المعزلة المستخدمة في الإنشاءات	زجاج عدلي وثقلى السيكوريت للتوافل والأبواب	٧٠٠٧١٩٠٠	طن	٣٠٠
٢٥١١٥٤ - صناعة وتركيب التوافل والأبواب	ابواب الالمنيوم خارجية	٧٦١٠١٠٩٠	طن	٥٠٠
٢٥١١٥٤ - صناعة وتركيب التوافل والأبواب	شبيك الالمنيوم	٧٦١٠١٠٩٠	طن	٣٠٠
٣١٠٠٧٠ - صناعة المطابخ من الخشب والالمنيوم الخ	مطابخ وتشغلات الالمنيوم	٧٦١٠٩٠٩٠	طن	٣٠٠

التعليق

وزير الطاقة والصناعة والثروة المعدنية

خالد بن عبدالعزيز الفالح



عدد العمالة ٢٠ ( عشرون ) فردا

إجمالي التمويل ١.٢ ( واحد و اثنان من عشرة ) مليون ريال

ملاحظة هامة: التعليمات خلف الترخيص متصلة له

تنتهي صلاحية الترخيص بتاريخ: ١٩/٠٣/١٤٤٣ هـ



## شهادة سعودة

تاريخ الإصدار : ١٤٤٦/ ٣/١٤  
تاريخ صلاحية الشهادة : ١٤٤٦/ ٥/١٧  
رقم الشهادة : ٣٤٥ . ٢٠١٠ . ٢٠٠٠

اسم المنشأة: مصنع الريادة الآلي للصناعات المعدنية

رقم الملف: ١٨٩٣٤٤٦-١

سجل تجاري: ١٠١٠٣٠٦٤٩٣

الصادر من: الرياض

تشهد وزارة العمل والتنمية الاجتماعية بأن المنشأة المذكورة أعلاه حققت نسب التوطين المطلوبة منها..  
وتم منحها هذه الشهادة حسب طلبها

(الشهادة معتمدة من صاحب الصلاحية ولا تحتاج إلى توقيع أو ختم)

تنبيهات:

١ - يمكن التحقق من صحة وصلاحية الشهادة عبر زيارة الرابط: <http://mol.gov.sa/CERT>

٢ - في حال اكتشاف أي عملية تزوير في الشهادة المقدمة نرجو التبليغ عن ذلك بخطاب رسمي للأقرب مكتب عمل.



SERIES 120 mm

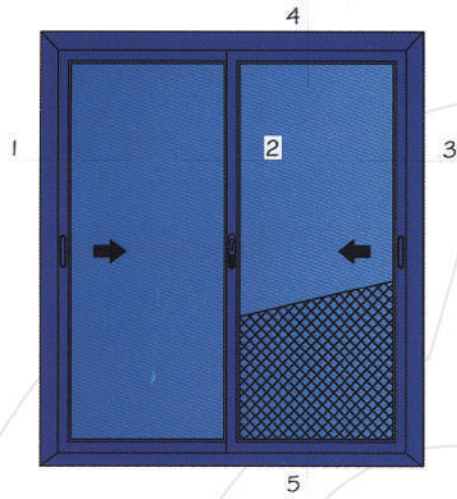

VERTICAL SECTION  
( 4-5 )

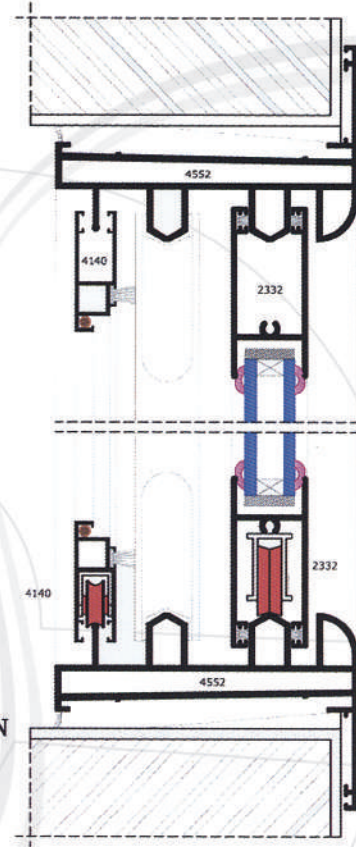

HORIZONTAL SECTION  
( 1-2-3 )

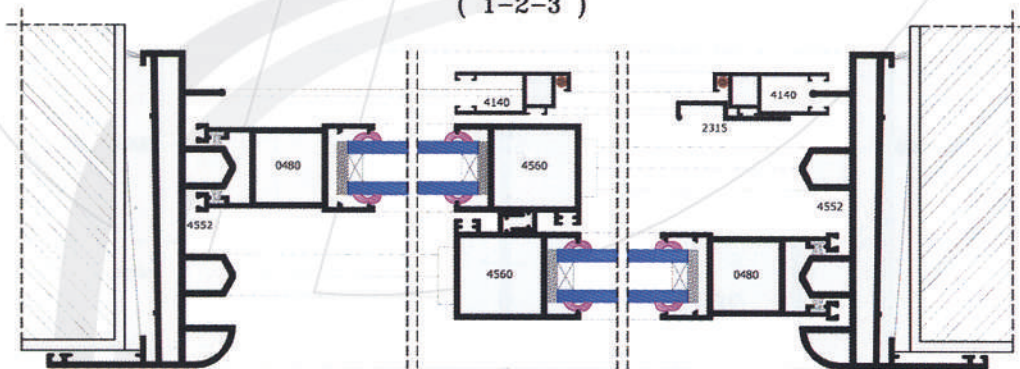





CURTAIN WALL SERIES 61.50MM

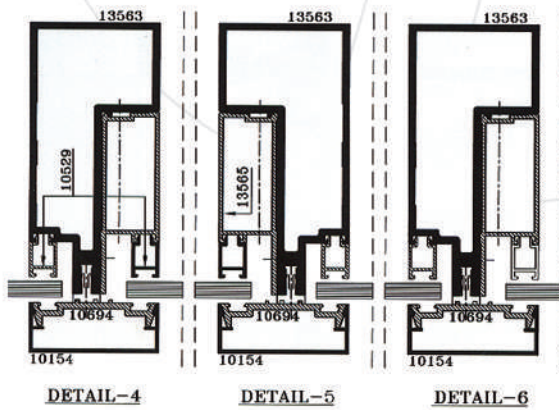
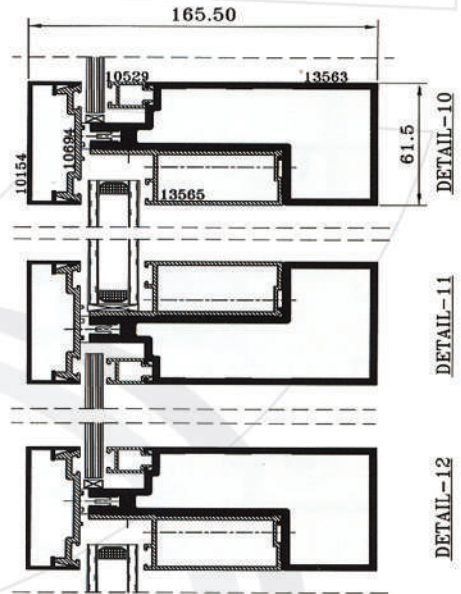
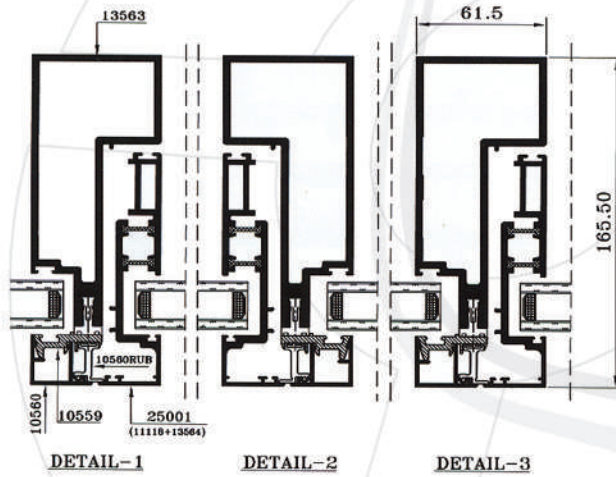
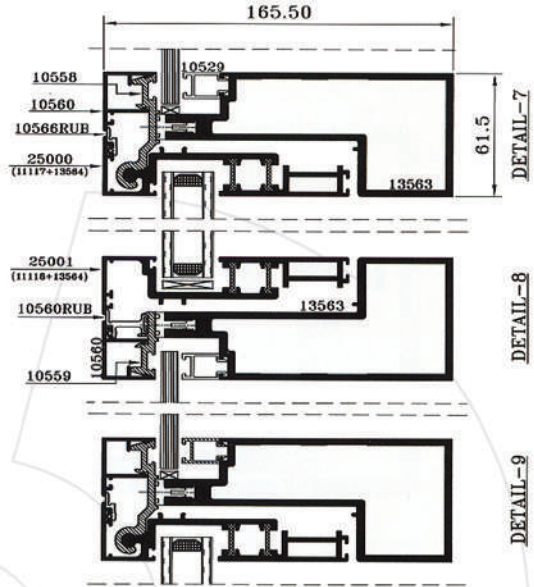
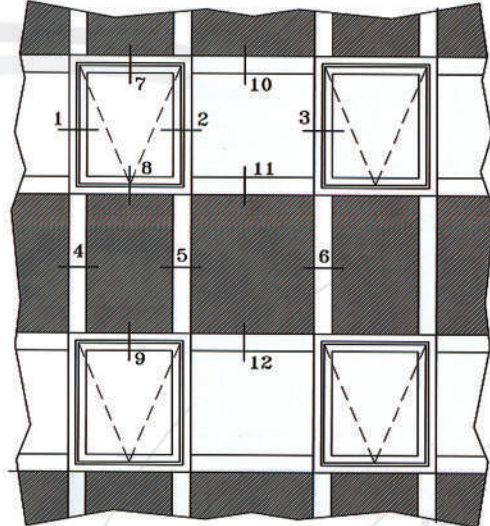

IMPORTANT NOTES

- A. MINIMUM HEIGHT FOR CONSEALED VENT IS 700MM.
- B. MAXIMUM ANGLE OF ROTATION NOT TO EXCEED 40°.
- C. FOR A HEIGHT OF 700MM WINDOW WILL OPEN AT A DISTANCE OF (APPROX.) 356MM OR 14 INCHES .
- D. AS THE HEIGHT OF THE WINDOW INCREASES SO WILL THE WINDOW OPENING PROPORTIONATELY INCREASE

CW/61.5/B/04

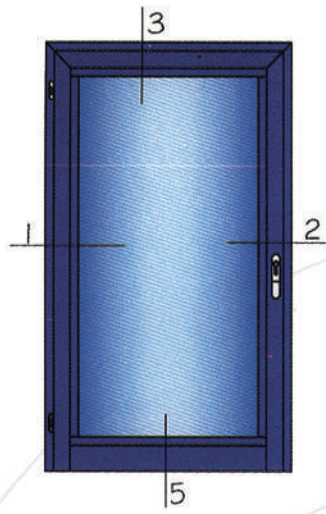

VERTICAL SECTION  
( 3-4 )

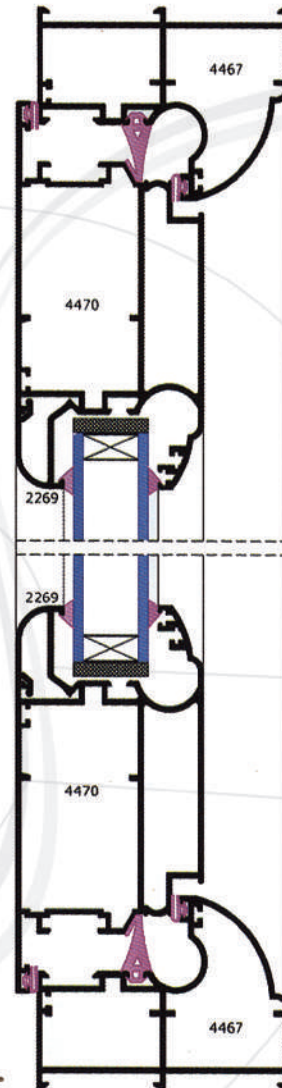

HORIZONTAL SECTION  
( 1-2 )

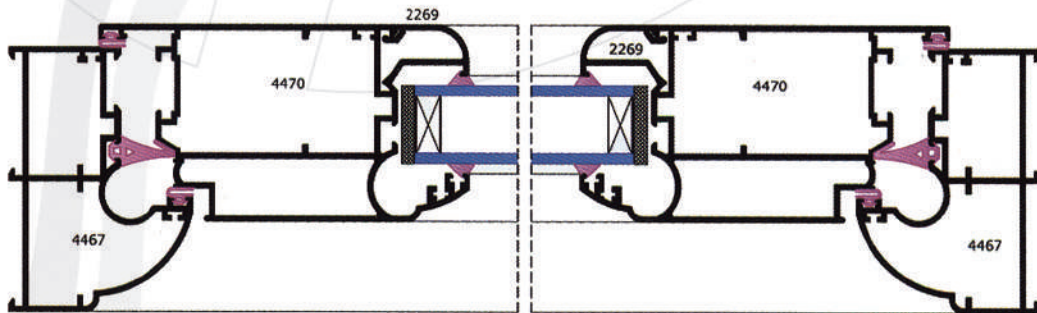



THERMAL BREAK  
VORTEX SERIES (70MM)

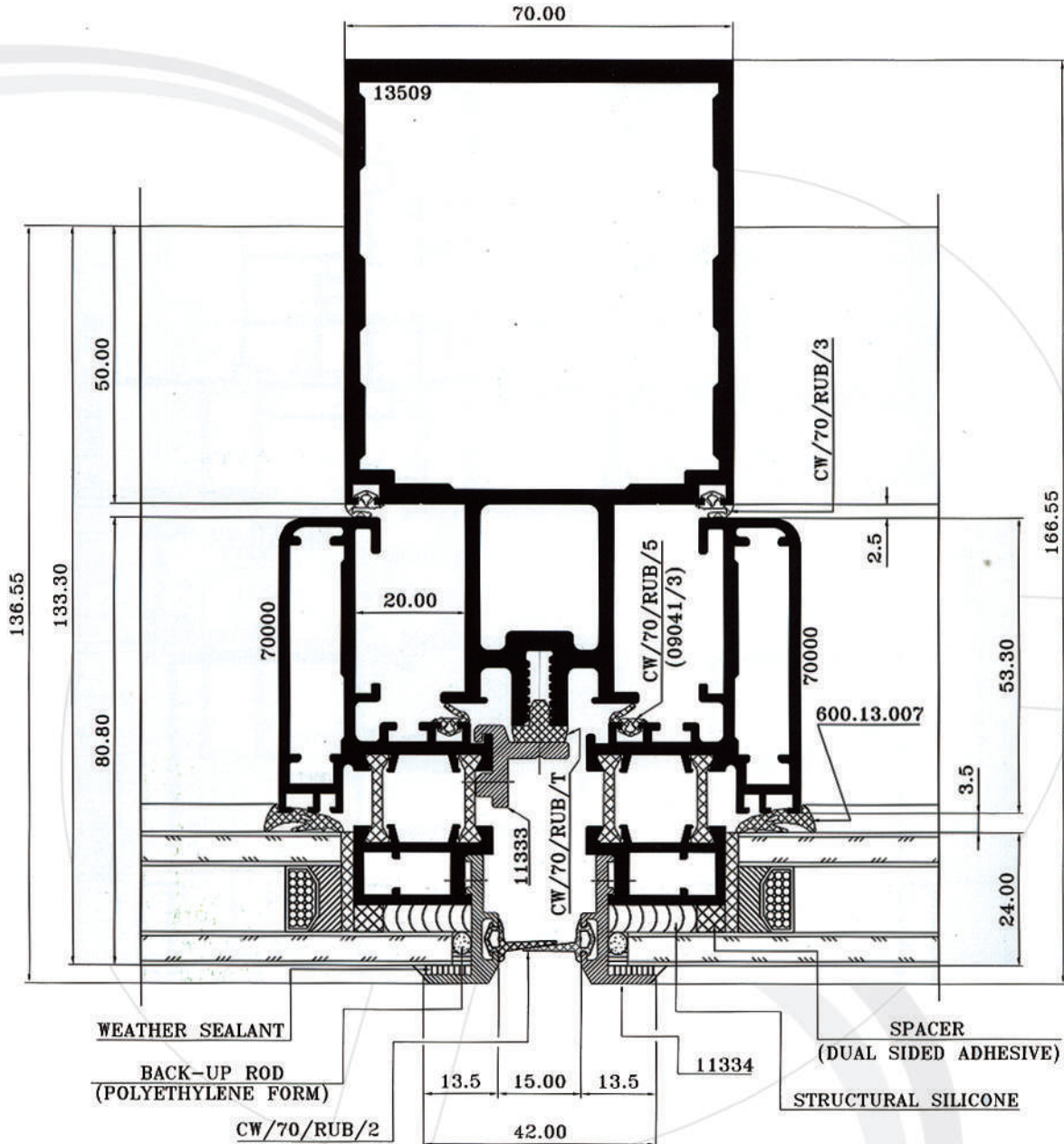

DETAIL-X

VORTEX CURTAIN WALL SERIES  
(THERMAL BREAK)  
STRUCTURAL GLAZED (70MM)  
CW/70/TB/X  
(01/09/96)

نظام كرتن وول ترمل بريك



### Magnum "MIS" Series

Standard 4-Bar geometry for structural glass vents. Available in 10" (254mm) and 16" (406mm)

Part Numbers :

210MIS (10" - 254mm)  
216MIS (16" - 406mm)

"Easy to access" friction adjustment screw allows you to fine tune vent operation and hold open position

Standard "Balanced Geometry" provides easy vent opening and operation.

Stainless steel "adjustable limit stop" is intergrated into the track and adjusts to many desired vent openings. Standard on all hinge sizes.

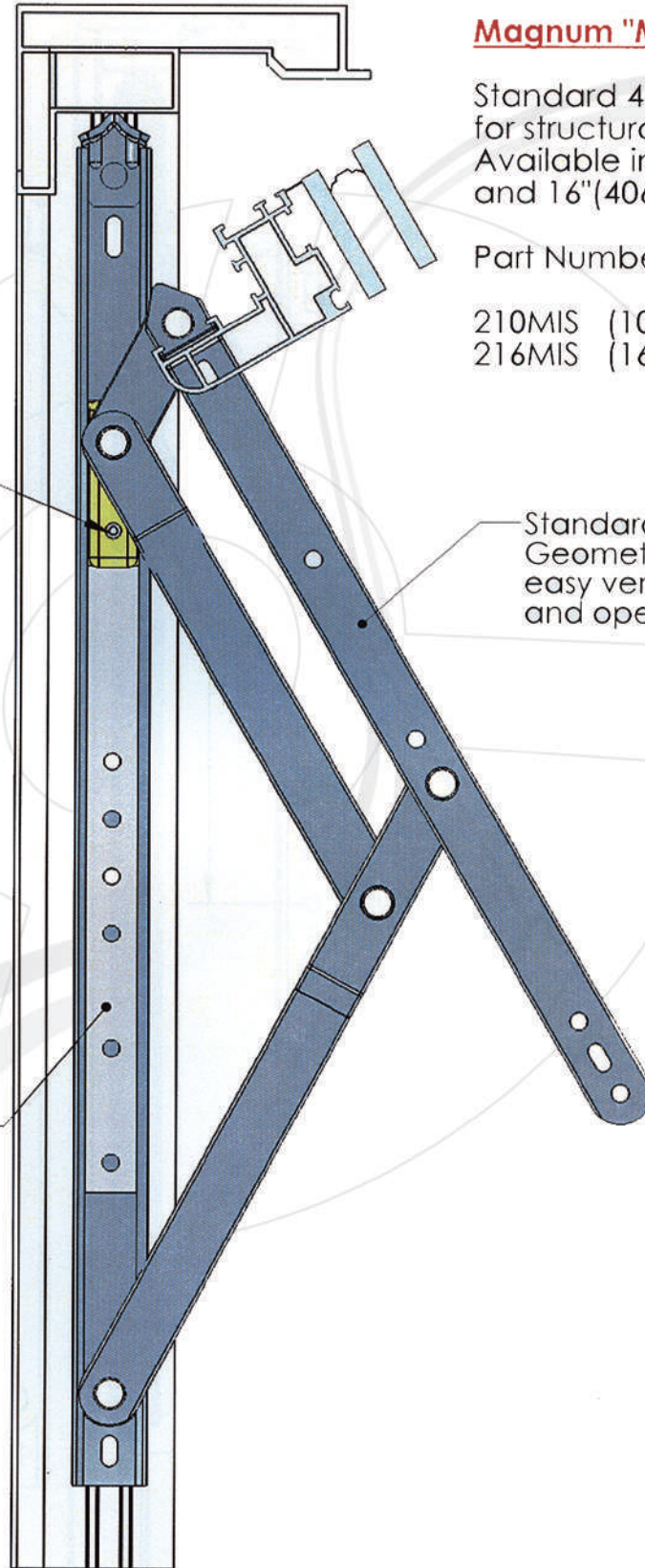



STRUCTURAL GLAZING

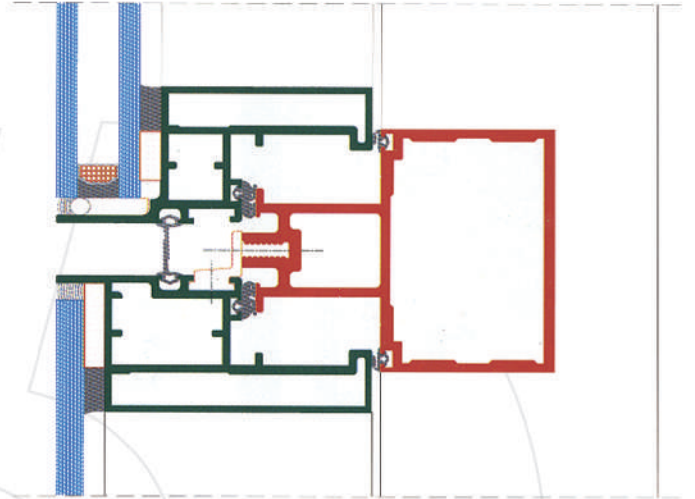
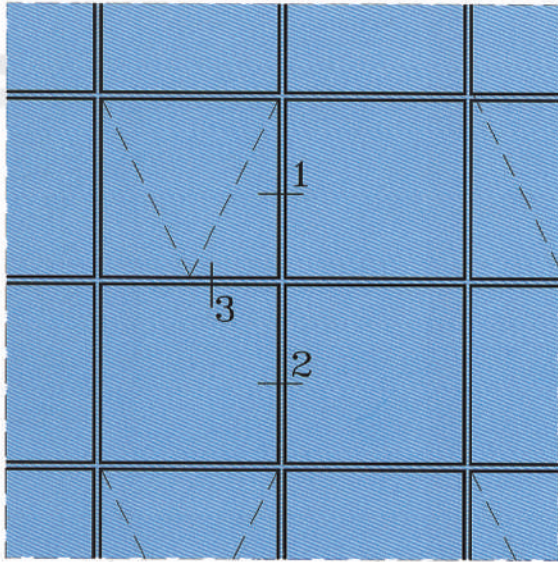

DETAIL-3

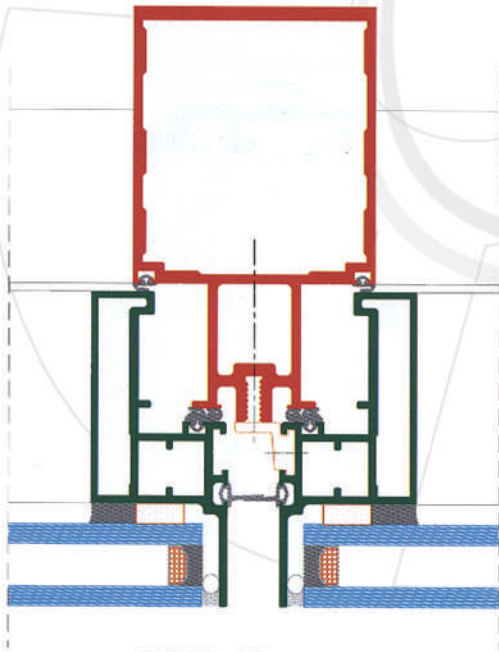

DETAIL-1

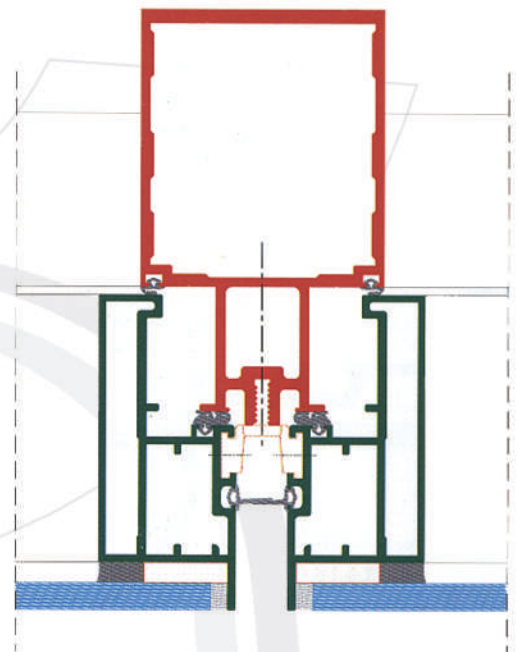

DETAIL-2

VORTEX CURTAIN WALL SERIES  
4 - SIDED  
STRUCTURAL GLAZED (70MM)  
CW/70/4SS/GEN  
(15/11/02 SUPERSEDS 01/10/94)

نظام كرتن وول ترمل بريك



THERMAL BREAK

VORTEX SERIES (70MM)

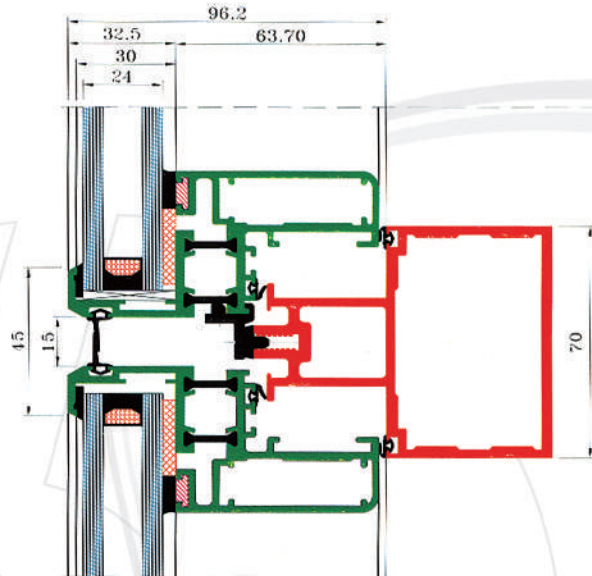
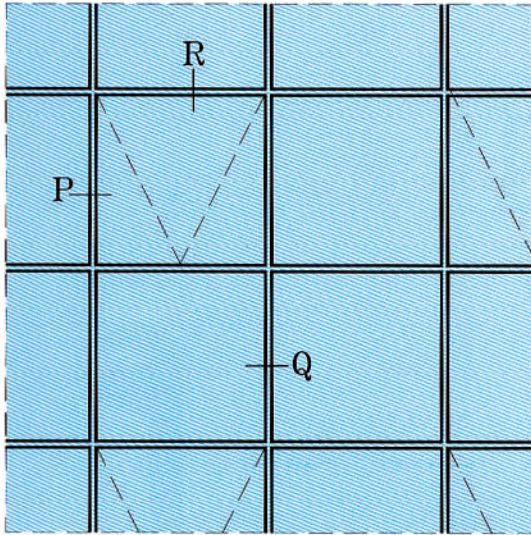

DETAIL-R

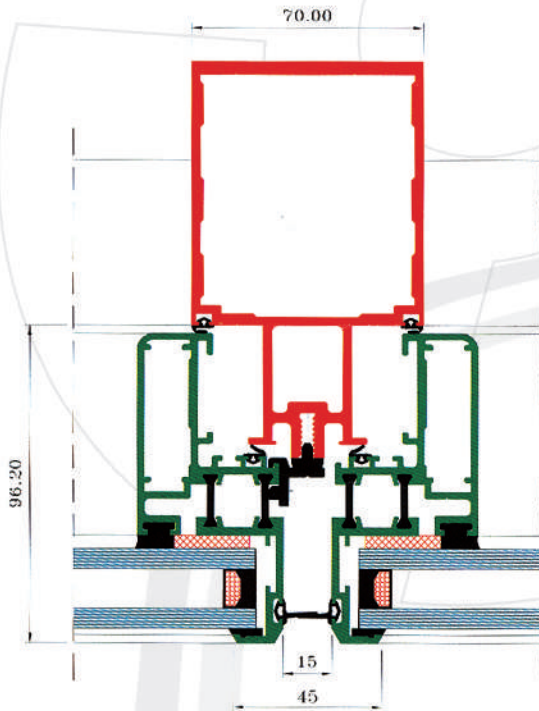

DETAIL-P

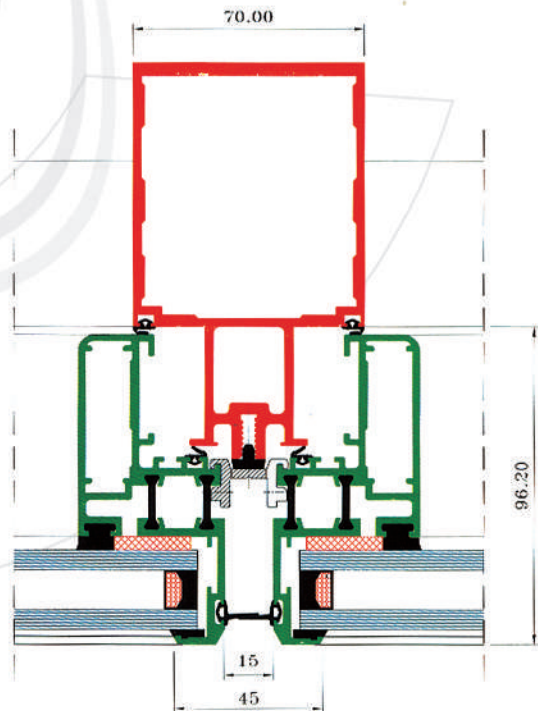

DETAIL-Q

VORTEX CURTAIN WALL SERIES  
(THERMAL BREAK)  
STRUCTURAL GLAZED (70MM)  
CW/70/TB/M12

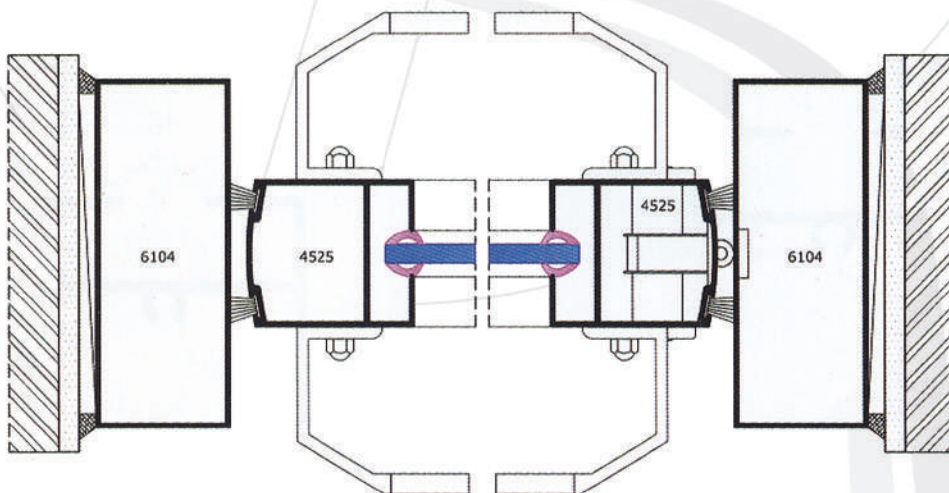
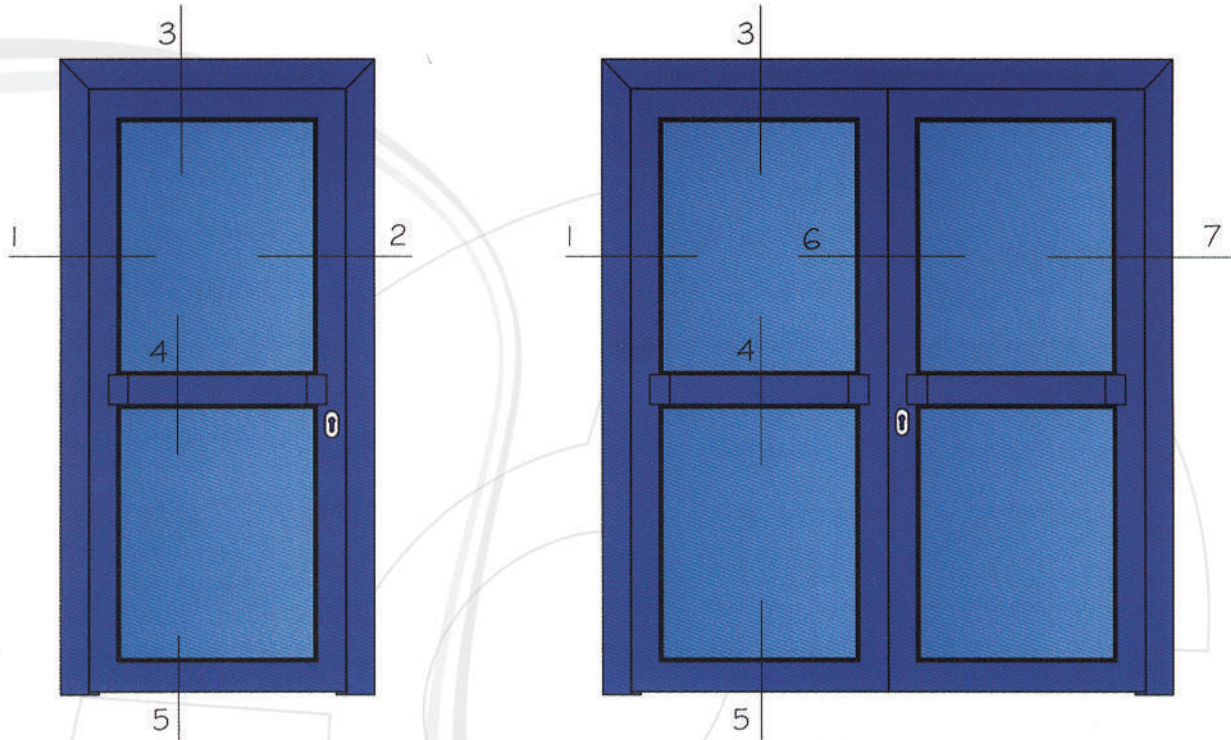

HORIZONTAL SECTION  
( 1-2 )

أنظمة أبواب دبل / سنجل



We always use the best accessories and high-quality species of the World secured and the door handles and machines, accessories of glass doors and locks, glass panes, lexan.

Some species of accredited agents installed :

Smart Aluminum System



Laval Accessories From Italy



Geze Accessories From Germany



Corbin Locks From Italy



Somfy Shutter Motors From France



Giesse Accessories From Italy



Aluminum Cladding Sheets ( Dareen )



Record Swiss Automatic Doors



Sun Guard Protecting Glass From Alwakeel







Dorma Accessories & hardware



Jolly Shutter Motors From Italy



Alulux Shutter From Germany



Sanhi Glass Hardware



SANHE HARDWARE

Sika Silicon Sealant



Luxaflex Venation From Holland





## Frameless glass door patch accessories:

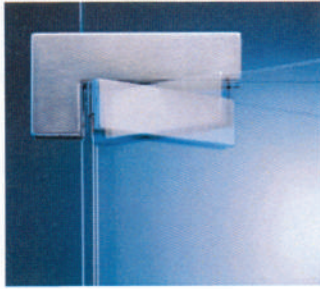

With its broad spectrum of basic types and variants, the DORMA Universal range of patch fittings enables the realization in toughened glass of almost any conceivable design. Toughened glass assemblies can be provided with fixed parts in widely differing arrangements - with corner fittings or fin fittings at different angles, and with double or single action doors in single-leaf or double-leaf designs.

## Frameless glass door lock:



Quality materials and thorough workmanship mean that DORMA SG locks have the features necessary to meet the most demanding of specifications. Many satisfied customers will testify this. For safety reasons set lock case always on inside.



## Frameless glass door floor spring:



Especially designed for fire doors, the BTS 80 F has a wide choice of functions such as electro-magnetic hold-open (EMB) and free swing (FLB).

## Rolling shutter:

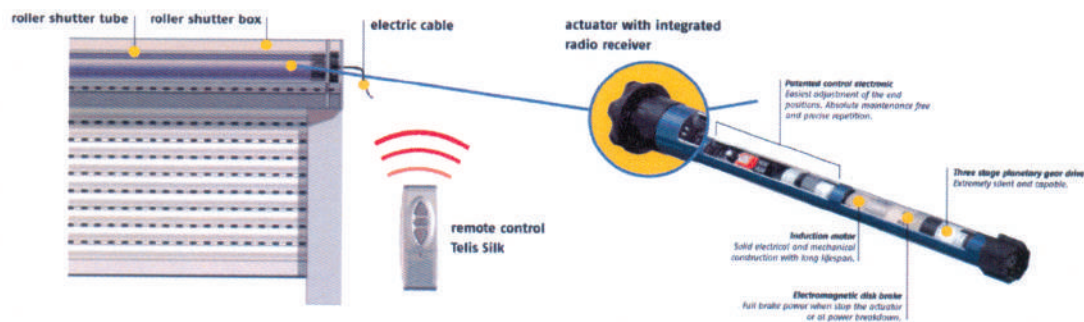

It is widely known that rolling shutters offer style, security and sun protection in any home. They can alter the shading of your room and offer complete privacy whenever you desire. During colder months, shutters can reduce heating costs via their insulation properties and in summer, they'll keep your home cooler, by reducing glare and heat from the sun. Rolling shutters are also great at reducing outside noise

The **RTS** motor is installed inside the shutter roller tube. It is connected to the control points by a radio receiver. Raise, lower and stop commands are sent to the receiver via a remote control.



## Sliding window handle:

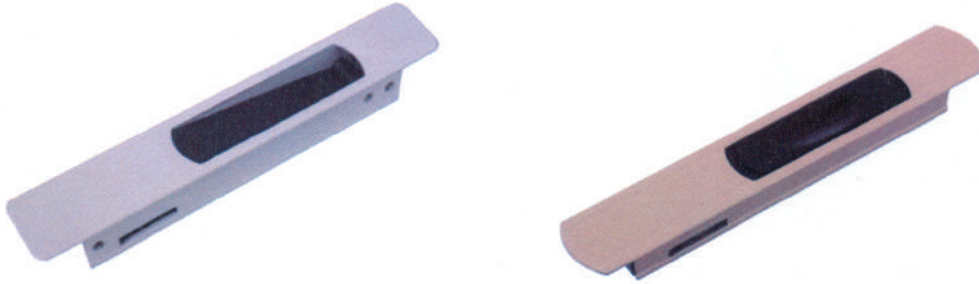

Lateral closing gear for sliding windows and doors in extruded aluminum, galvanized steel pre-assembled grub screws M6x8 and M6x20 (9010 W=with white nylon lever).

## Sliding window roller:

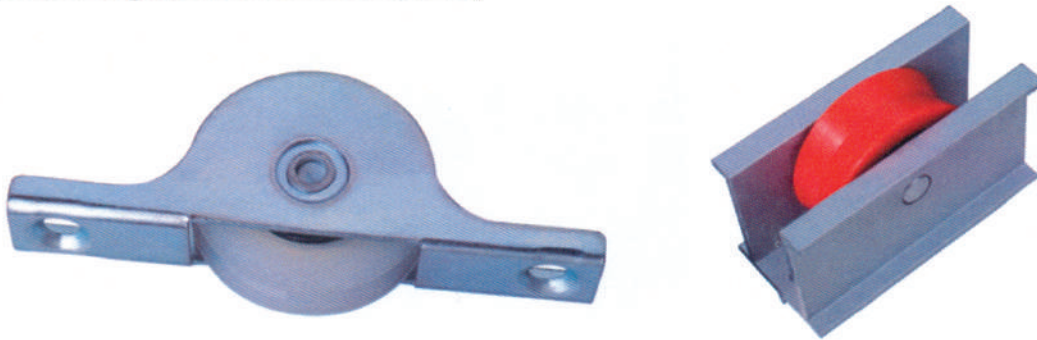

High quality nylon roller for sliding windows and doors in extruded aluminum, galvanized steel



## Casement window handle:



Handle for casement in die-cast metal or brass, dist. between centers 84.5-98 mm, 2 socket head cap screws M5x14 in black galvanized steel (for C and OTT finishes 2 socket head cap screws M5x10). PVD X, PVD H and OTT

## Casement door & window hinge:

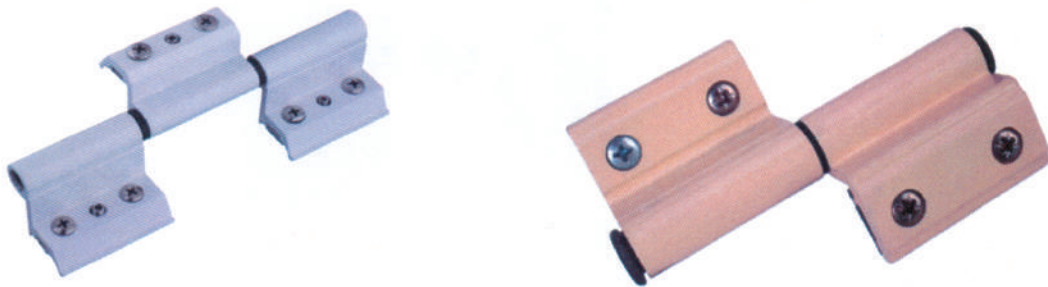

Two or three-wing hinge in aluminum, 2 nylon bushings, galvanized steel pin, preassembled counter plates and 4 countersunk oval head screws M5x10 in stainless steel 430. Carrying capacity: 2 hinges Kg 60, 3 hinges Kg 70.

Renewed version with oversized diameter and new indented counter plate



## Awning window latch:

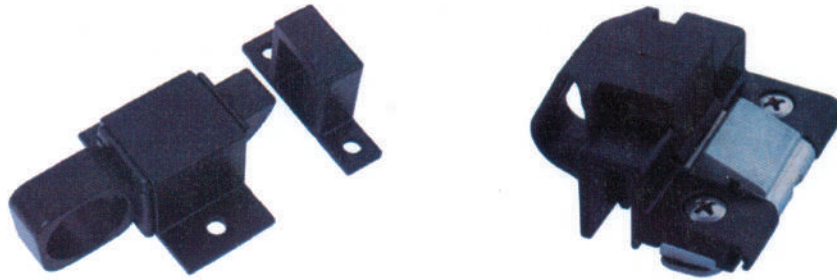

Aluminum catch, 3 nylon spacers, 2 countersunk head screws 4.5x16 and 2 countersunk head screws 4.5x9.5 in black galvanized steel

## Awning window arm holder:

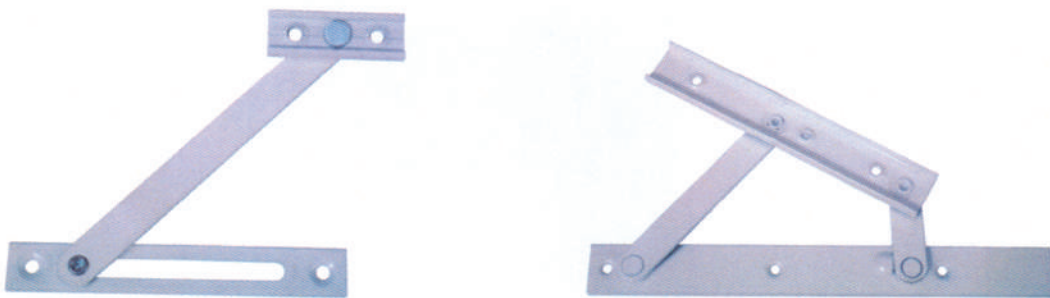

Window-holder arm stay in stainless steel 304 and 5 countersunk head screws 4.8x16 in galvanized steel. Suitable for profiles with minimum clearance of 13 mm



## Casement & sliding door handle:



Non-handed double door handle in nylon, with pre-assembled return spring, 8x120 mm square spindle and 4 cap screws 4.5x19 in galvanized steel

## Casement door lock:

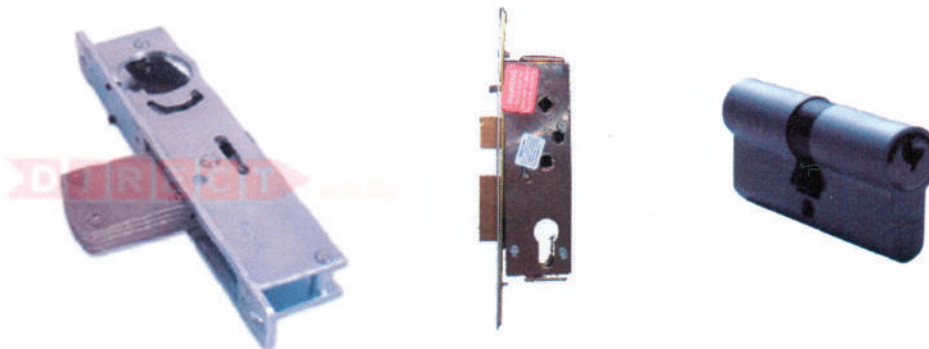

Latch is automatically deadlocked when door is in the closed position. All faceplates and strike plates must be ordered separately. Available in both deadlocking and self latching versions. Can be operated by either side by any standard bored type cylinder or 1000 series turn. For end finish comes in aluminum and the case finish is steel plated. Mechanism: Screw In Cylinder.



## Casement door closer:

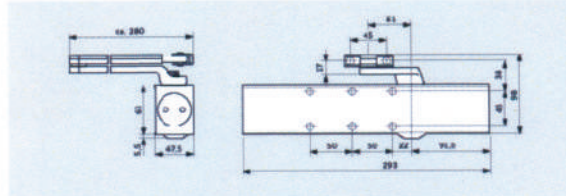
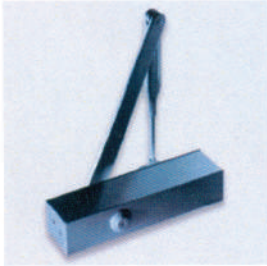

The door closer is particularly suitable for external doors up to 1400 mm wide. It offers enhanced convenience through its delayed action feature, plus added safety thanks to its adjustable, self-regulating back check. Its closing force can be infinitely varied between the spring strength values EN 3 and 6 by means of an adjustment screw

## Casement door stopper:



This door stop stands 40mm high (floor mounted) and has a 38mm diameter metal core with a 50mm diameter rubber band around the hole door stop. It gets affixed with one screw in the centre. A 30mm screw is included and for mounting into concrete or similar floors a raw plug is also included. This is a heavy duty door stop and because it is round it is very easy to install.





## Sliding door operator machine:

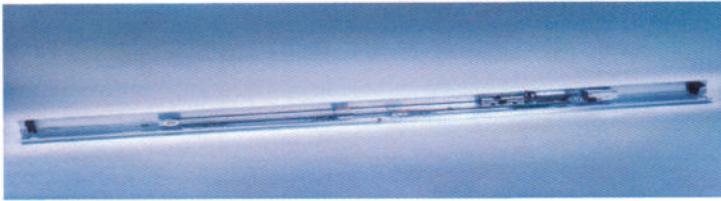

The DORMA ES200 is an elegant and functional unit that has been designed to meet the requirements of every automatic sliding door application. The DORMA ES200 is a completely redesigned sliding door operator that encompasses:

A stylish and modern cover design that features clean contours and perforated end caps to complement your design scheme.

A choice of three cover sizes which allow greater flexibility to suit your application, from 100 - 200mm cover.

A new motor that ensures a virtually silent operation.

A new microprocessor that automatically controls the opening and closing speeds of the door, ensuring the highest possible safety at all times.

New rollers combine with the microprocessor give our smoothest ever automatic door.

A new electric lock with a self-testing function that ensures the doors are always secure.

A new energy saving power unit.

New programming functions allowing for quick and simple installation, set-up and maintenance.



المقر الرئيسي لشركة أثافي

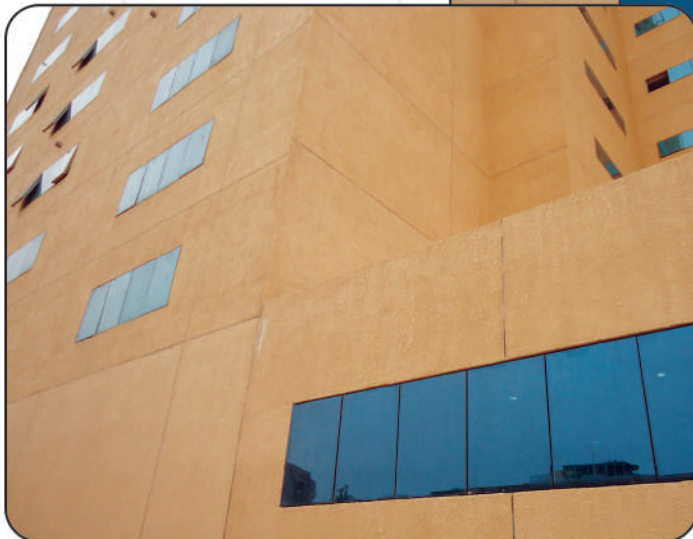

مشروع البيت (٥٦)

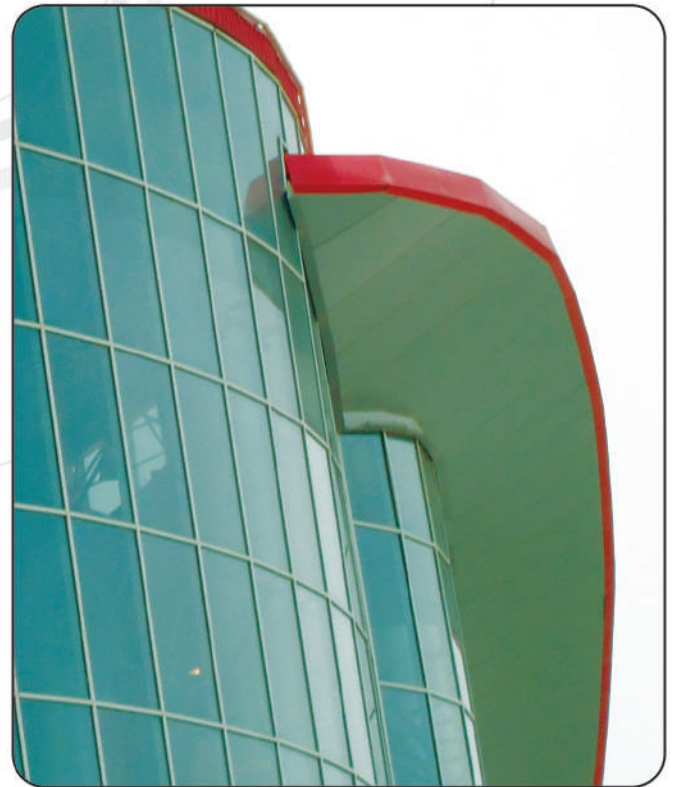



مشروع الهرم بلازا



مشروع البيت ( ٢٢ )







مشروع البيت ( ١٧ )



إنشاء ٥٠ فيلا - شركة البيت





قصر خاص - السليمانية



أعمال ألمنيوم وزجاج  
حي الياسمين



سلسلة مطاعم إيطالية



إنشاء ٢٠ فيلا شركة الراجحي

























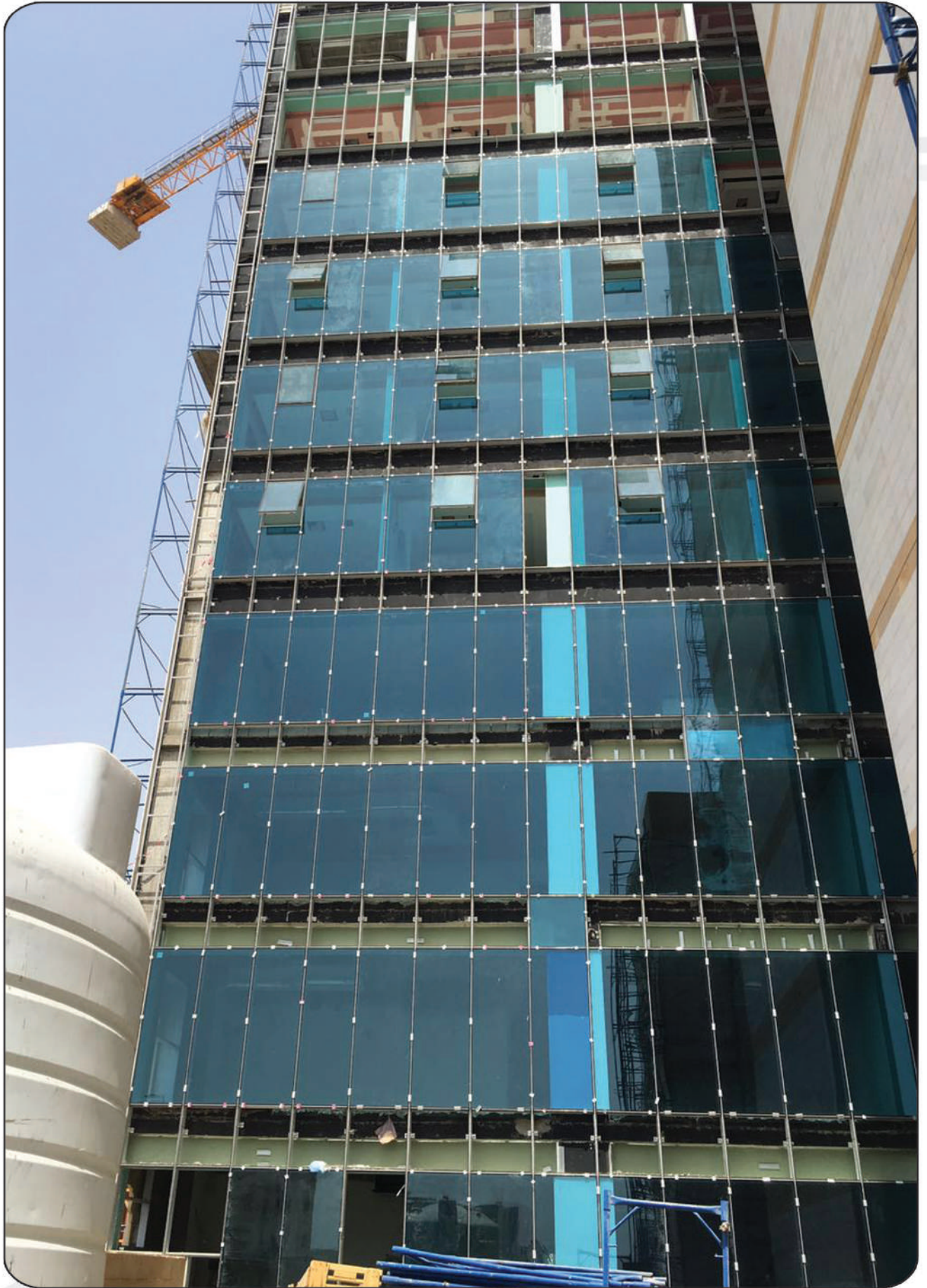















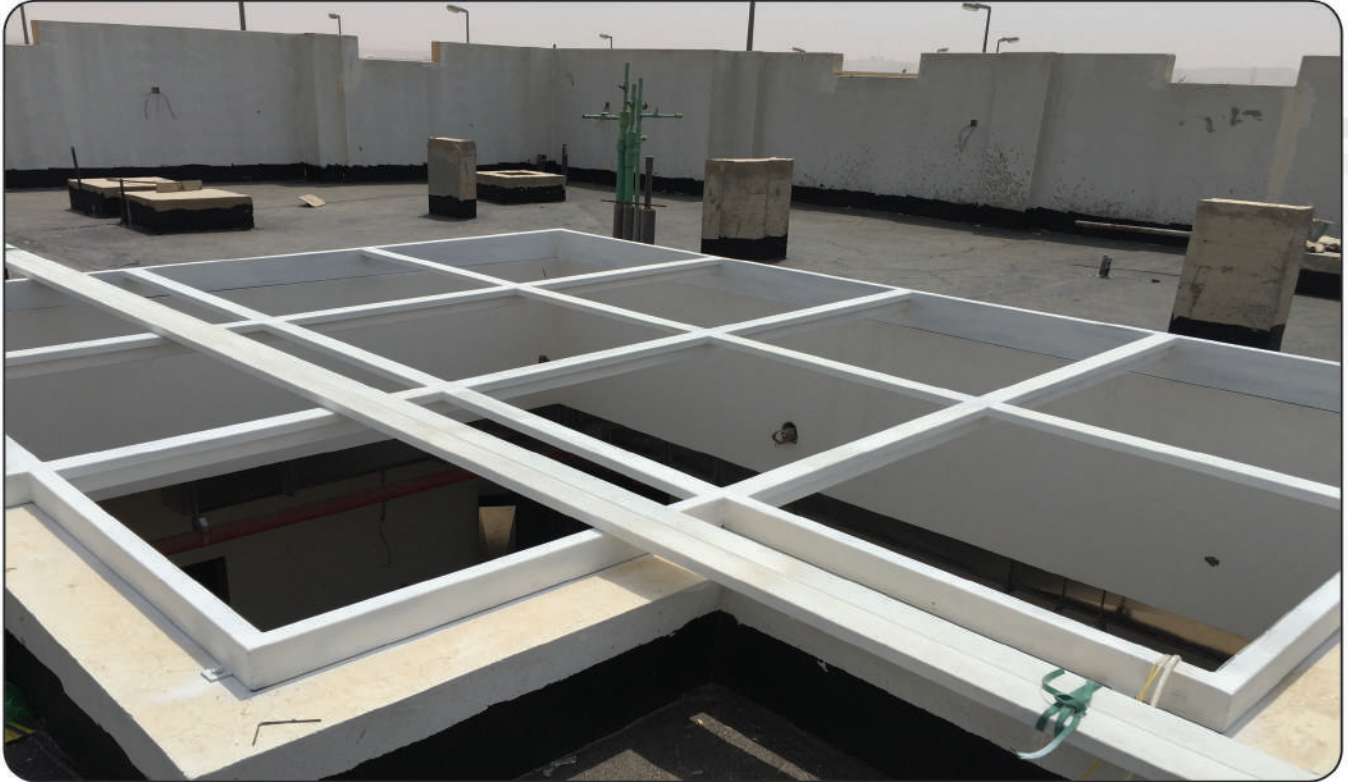







مصنع الريادة الالي للصناعات المعدنية  
AL-RIYADAH AL-ALIE FACTORY FOR METAL INDUSTRIES



**مصنع الريادة الالي للصناعات المعدنية**  
**AL-RIYADAH AL-ALIE FACTORY FOR METAL INDUSTRIES**

المملكة العربية السعودية - ص، ب ٣٩١٤٦ - الرمز البريدي ١١٣٦٥ - هاتف : ٠١٢٧٠٢٤٤٦ - فاكس : ٠١٢٧٠٥٦٢٢ - جوال : ٠٥٥٧٦٥٥٥٢٢  
Kingdom of Saudi Arabia - P.O.Box 39146 - P-Code 11365 - Tel.: 01 270 2446 - Fax: 01 270 5600 - Mobile: 0557655522

E-mail: [alriyadah\\_sa@hotmail.com](mailto:alriyadah_sa@hotmail.com)